

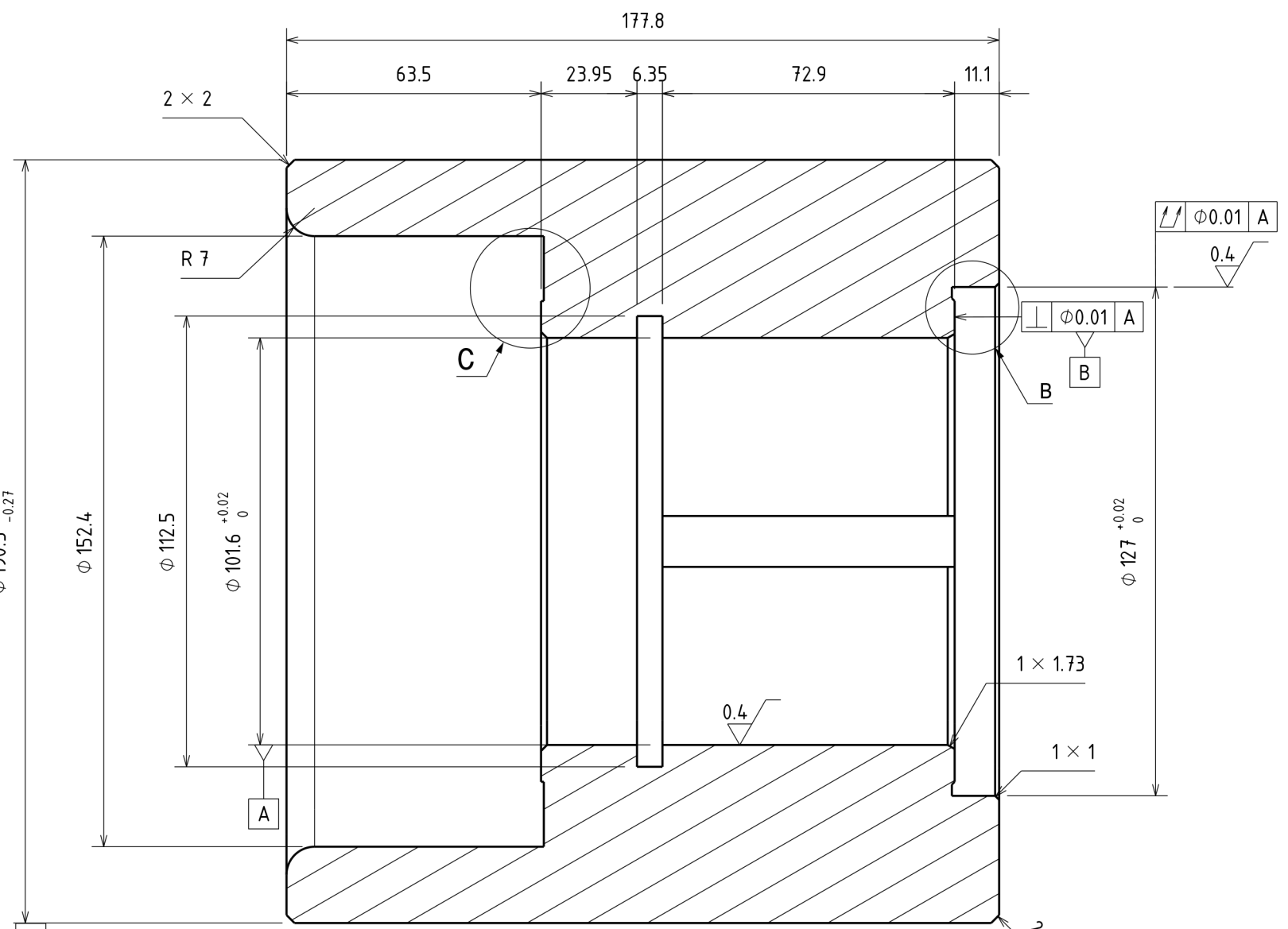

Detail B
Scale: 4:3

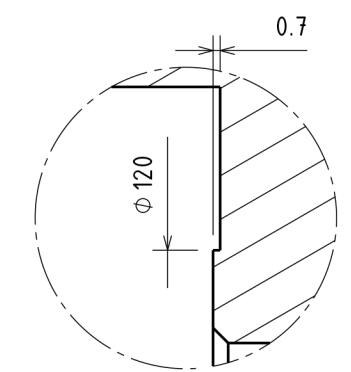

Section view A-A
Scale: 2:3

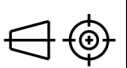

Detail C
Scale: 4:3

Montazer Ghaem Power Management Co. 		DIMENSION WITHOUT TOLERANCE ARE ACCORDING TO ISO2768(M)		SCALE: 1:3	QTY: 1	WEIGHT (Kg): 22.6
				MATERIAL: ASTM A276 T.420 - 45HRC		UNITS: mm
				PART NAME:		
				PISTON BALANCE		
				PART NO.: 118005002		 SIZE: A3 SHEET 1/1
NO.	REVISION	DATE	NAME	CLIENT:	CLIENT PART No.:	